



**PRODUCT SPECIFICATION**

Product Line: **EVSE**

Product #: **3704** Version #: **Axxxx**

**Smart Level 2 EVSE with Automatic Cable Management, Wall/Single Pole/Dual Pole Mount**

The Model 3704 electric vehicle charger provides 208 - 240V AC up to 30A. Designed as per the SAE J1772 requirements to meet or exceed all safety codes specified by UL and NEC, the unit is engineered for either exterior curbside pole mounting (single or dual) or wall mounting, while meeting or exceeding all NEMA 3R specifications. In addition, a power disconnect switch is installed to easily remove input power to the charger for any maintenance or cycle testing.

The charger is equipped with a state of the art cable management system, which fully retracts and protects both the cable and the connector from harsh weather and vandals. The cable management system is ADA compliant and eliminates tripping hazards.

Modular in design, the charger can be configured for simple On-Off control, or for more demanding requirements of credit/debit and ID card processing through the addition of an optional Payment Module. Serial or Zigbee connections are available for facilitating communication between the 3704 and Payment Module. A single serial Payment Module can support from one to eight 3704s, depending upon its configuration. ZigBee networks, allowing wireless connections, are secured by 128-bit symmetric encryption keys, so security is assured. A single ZigBee Payment Module can support up to 32 remote 3704s.

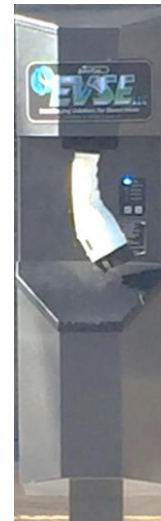

Description: The Model 3704 is a 7.2 KW wall- or pole-mounted EVSE charger with AutoCoil™ cable retraction, capable of providing up to 30A at 208-240VAC, single phase at 50/60 Hz. It is configurable as a single wall mount, or a single or dual pole mount. This unit complies with the SAE J1772 specifications for supplying electrical power to a J1772-compatible Electric Vehicle (EV). When the 3704 has been activated for a charge cycle, the user simply pushes the button on the J1772 connector and the charger will automatically dispense the cable until the button is released.

Data Router: The Data Router in the charger can be supplied with a basic ON/OFF keyboard for either free use or use in conjunction with an optional Payment Module. The charger can also be equipped with a Data Router with an RFID card activation, and a Handbook 44-compliant display module to display Kilowatts (kW) used and the associated cost. The Handbook 44-compliant Data Router displays the data collected by an EUMD Module (End-User Measurement Device), which is an internal revenue-grade meter that measures power dispersed to the vehicle during a session with 1% or better accuracy. The EUMD can also be installed and used by itself to send power measurements back to the host.

Cable Management: The J1772 power cable is stored in a weatherproof enclosure when not in use, and locked in place for protection from vandals. When a valid charge activation is received, the connector is released, the user simply pushes the button on the J1772 connector, and the cable is automatically dispensed. When the button is released, the cable stops. Before plugging into the vehicle, the button can be depressed again if more cable is required.

When the connector is removed from the vehicle, the cable automatically retracts to the stored position.

Power Management: The charger provides up to 7.2 kW (208/240 VAC @ 30 A) to the electric vehicle when activated. Power is continually monitored and the charger disconnects power to the vehicle if the voltage deviates from the acceptable range, or if the load current exceeds the maximum level. Three re-closures are attempted to prevent nuisance service breaker trips. The charger can also receive *Load Shed* commands via host communication networks, signaling it to reduce power by either percent of total or to designated current levels, including simulated Level 1 (7A). In addition, a Control Module Power Share cable can be installed to allow two 3704 chargers mounted on a pole to operate off a single service panel breaker. If a 40A breaker is used, both chargers can be used to provide 16A to the vehicles (or the full 30A when only one charger is being used). If a 50A breaker is installed, both chargers can be used to provide 20A to the vehicles (or the full 30A when only one charger is being used).

The 3704 also includes a Random Start feature. In the event of a deep voltage sag or momentary power outage, it delays its restart for a random time period of between two to five minutes after the power has been restored. Once the charger restarts, it *ramps up* to the required maximum power at a rate of 1A/second. This prevents power surges when restoring power to multiple chargers.

Label Description: **Intelligent Power Controller EVSE**

Product Code: **3704-Axxxx**

© EVSE LLC 2017. All Rights Reserved. This specification is confidential and shall not be duplicated, published or disclosed, in whole or in part, without prior written permission of EVSE LLC. This specification is subject to change without notice.

Marketing: DS

Engineering: GC

Date: 11/17/17

Date: 11/17/17

**EVSE LLC, 89 PHOENIX AVE., ENFIELD, CT 06082 PHONE (860) 745-2433**

4/23/2018

Page 1 of 4

Safety:

The charger is equipped with a Ground Fault Circuit Interrupter (GFCI). The GFCI circuit is tested at the beginning of each charge cycle. If a ground fault occurs during the charge cycle, power is removed from the vehicle, and three re-closures are attempted to see if the ground fault clears. If not, the user sees a message indicating charging is not taking place. A message of the event is also sent to the host network. When the cable is removed, it automatically retracts.

The charger is also equipped with a Plug-Out Detection circuit that identifies when the connector is removed from the vehicle. This allows the charger to immediately remove power from the electric vehicle and start the cable retraction procedure. A message of the event is sent to the host network.

The 3704 also includes a power disconnect switch for quickly removing input power to the charger for any maintenance work or cycle testing.

3704 Mechanical Drawings (Dual Illustrated, Relevant Dimensions Apply to Single Pole and Wall Versions):

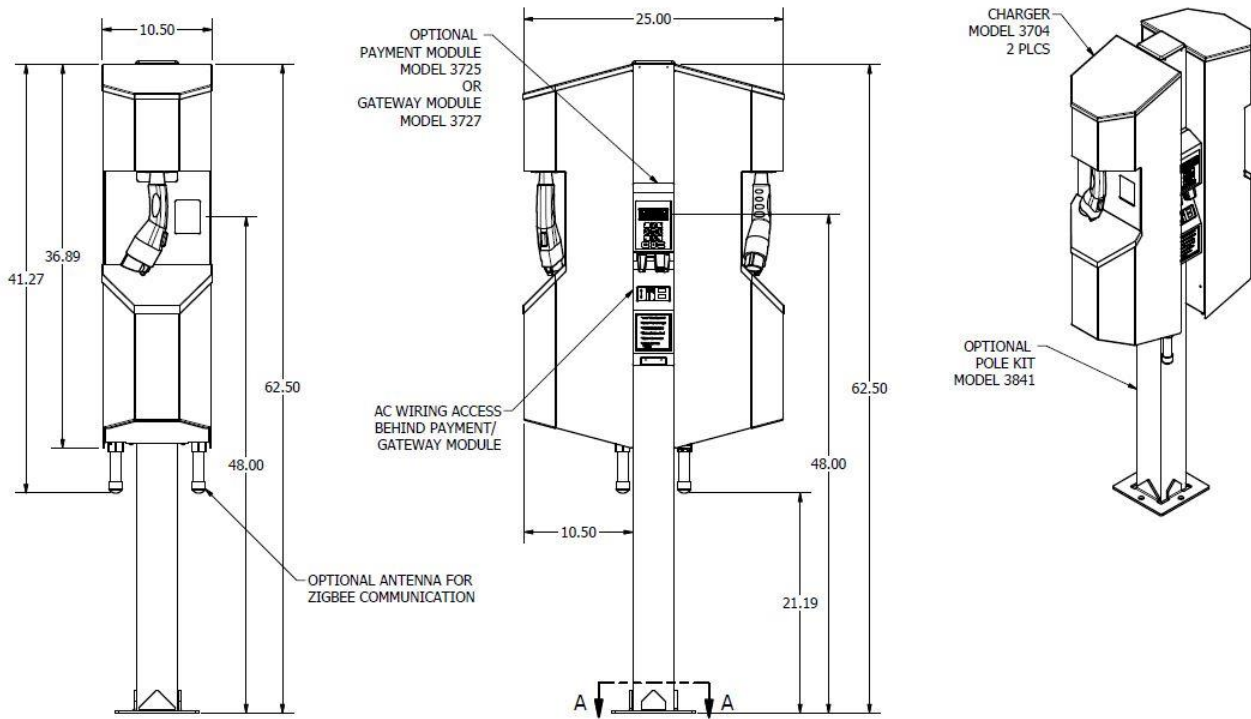

3704 Pole Base Mounting Dimensions:

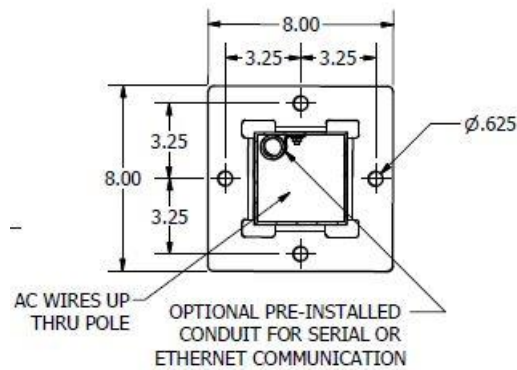

Specifications

Electrical Input:

Power Input: 7.2 kW  
 Voltage Input: 208-240 VAC 50/60Hz  
 Current Input: 30A  
 Breaker: 2 pole 40A breaker **Non-GFCI** on a dedicated circuit (1 breaker for a single pole/wall; 2 breakers for a dual, each supporting an EVSE)  
 Stand By Power: Less than 6W typical (without communication operating)

Electrical Output:

Power Output: 7.2 kW  
 Voltage Output: 208-240 VAC  
 Current Output: 30A  
 Charging Connector: SAE J1772 EV Connector on an 20' retractable cord

Safety:

Compliance: IEC/UL/CSA C22.2 NO. 61010-1, UL2594, UL2231-1&2, NEC Article 625, SAE J1772  
 EMC Compliance: FCC Part 15 Class A, Canadian ICES-003  
 Surge Protection: 6KV @ 3000A  
 Ground Fault: Internal 20 MA CCID with auto re-closure (three attempts)  
 Ground Wire Detection: Continuous Monitoring  
 Over Current Protection: 32A for 1 min. with auto-reset when disconnected  
 Plug Out Detection: Power terminates as per SAE J1772

Functional Interfaces:

Local Area Network: ZigBee mesh protocol@ 2.4Ghz ISM (Serial, hard wired also available)

Environmental:

Enclosure: NEMA 3R  
 Vandal Proof: Cable is locked when stored  
 Operating Temp: -22°F to 122° F (-30° C to 50° C)  
 Operating Humidity: Up to 95% non-condensing  
 Wind Loading: Up to 160 MPH

General:

Dimensions 37 in (h) x 10.25 in (w) x 10.5 in (d) (Excluding Pole)  
 Weight 32 lbs. (Excluding Pole)